

# GRIND-ALL SUPPLY

- PRESENTS -

## Mini 4-Bolt Chipping Hammer

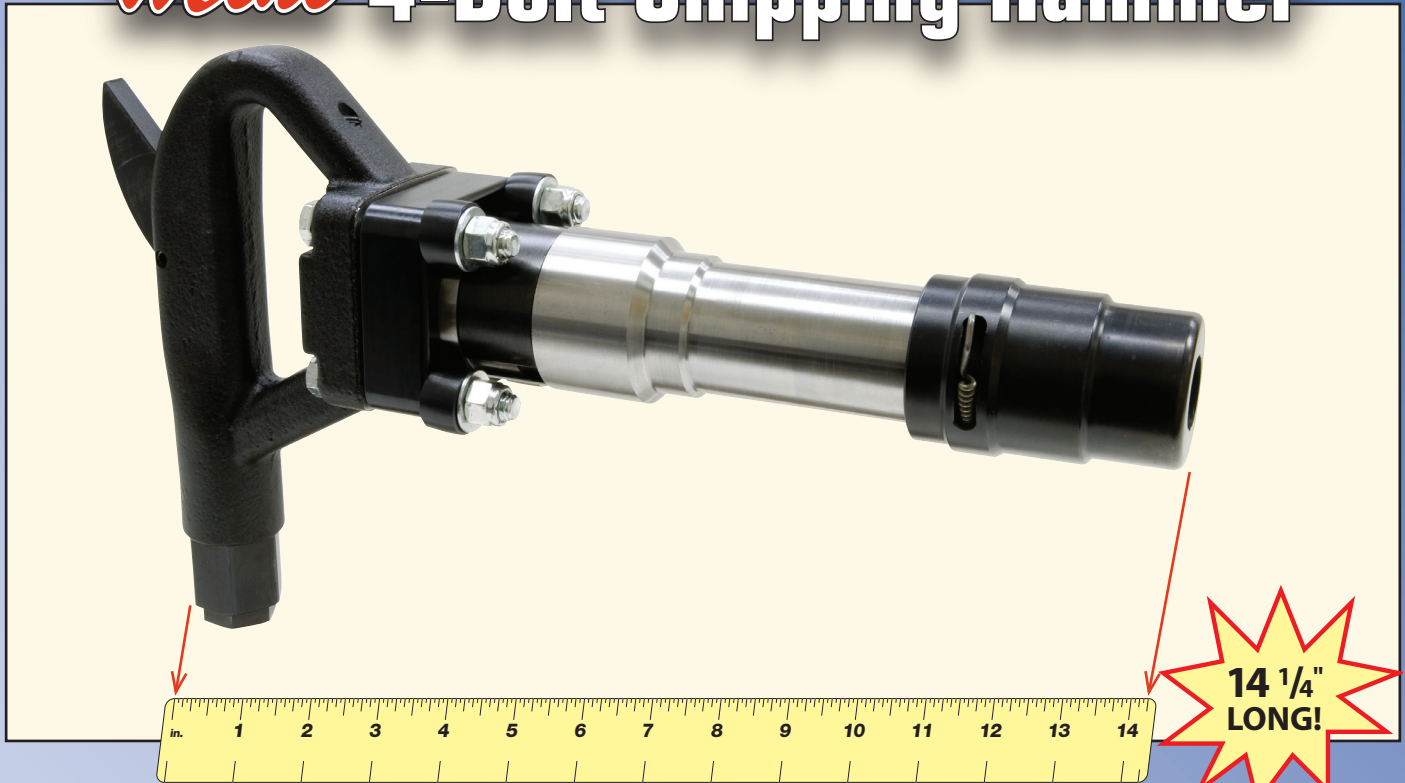

We are proud to present the **Mini 4-Bolt Chipping Hammer** manufactured in North America with the highest quality materials and tightest tolerances. The **Mini 4-Bolt** delivers the power we promised for the Foundry Industry. Our patented two-step piston design cycles at 2,750 blows per minute and is ideal for cleaning castings and forgings, as well as refractory, gunite, and brick work. The rapid cycling rate delivers powerful blows to remove sand, slag, or ceramic from the impact zones and surrounding areas.

The **Mini 4-Bolt** hits harder than any other 10 lb. chipping hammer currently on the market. If you want to increase production, reduce downtime, and offer incentive to your workforce, then you want the **Mini 4-Bolt** chipper in your facility today. We realize your most valuable asset is your workforce. Offer your employees the best tool for the job. Give them the **Mini 4-Bolt Chipping Hammer** from Grind-All Supply.

**You Simply Must Try It To Believe It!!!**

### Specifications

Stroke .....	2.6" (66mm)
Bore .....	1.1" (28mm)
Blows Per Minute (BPM) .....	2750
Length.....	14 1/4"
Weight (w/ Retainer).....	10.5 lbs.
Air Inlet Thread.....	3/8" NPT or 7/8-24
Average Air Consumption.....	17 cfm
<b>Model M4BLTH.....</b>	<b>0.580 Hex Shank</b>
<b>Model M4BLTR.....</b>	<b>0.680 Round Shank</b>

271-A Stephen Street • Morden, Manitoba CANADA R6M 1V2

Ph: (204) 822-9911 • Fax: (204) 822-9912 • [www.grindall.ca](http://www.grindall.ca) • e-mail: [grindall@mts.net](mailto:grindall@mts.net)